

ECHELLE 1:1

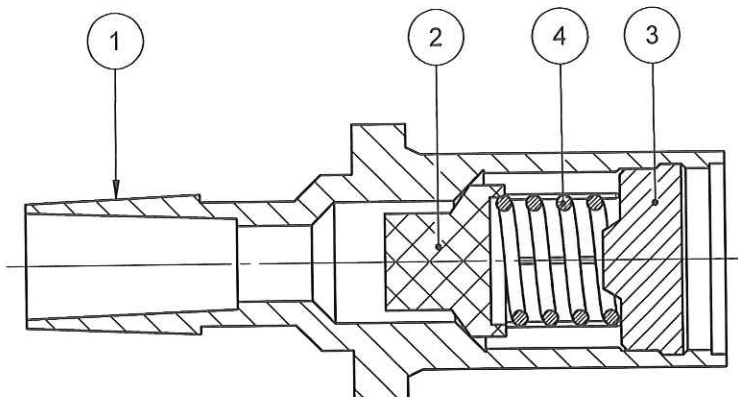

COUPE A-A

ORIGINAL

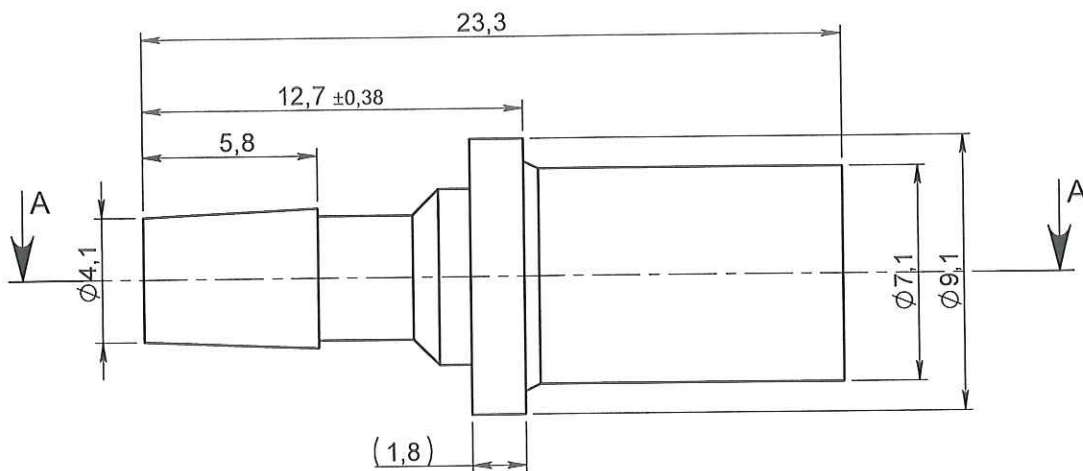
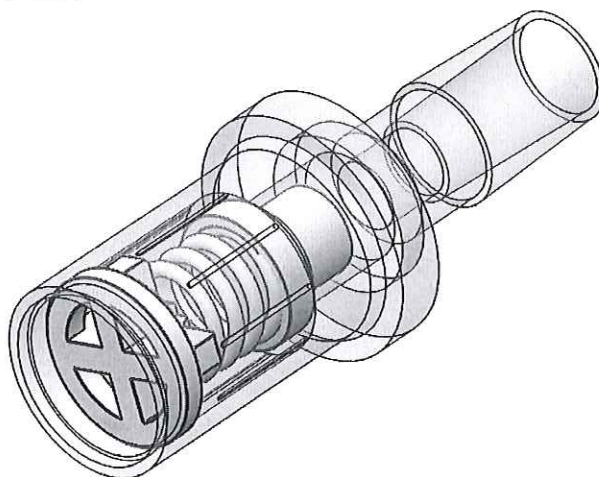

NOTA :

Rep.	Matière	Code matière
1	PC	M0223
2	SILICONE	M0556
3	PP	M0216
4	INOX	M0608

SPECIFICATIONS	
SPRING PRESSURE	6 PSI (±15%)

APPROBATION / APPROVAL		
Client / Customer :	Promepla Resp. BE : <i>DASCHIN</i> 17.02.2013 <i>[Signature]</i>	Promepla Qualité : <i>[Signature]</i> 23 AVR. 2014
Nom / Name, date & signature		

0	02/05/2013	BOUJMADA	Creation	FOR073 : 7140
Rev.	Date	Designer	Modifications	N° Fiche FOR073 ou FOR021

Normes :

Matière : VOIR NOTA	P. 1 / 1	Echelle : 4:1	
Code matière : VOIR NOTA	Revision : 0	Format : A4	
Reference : PBN00799	Tolérances générales : ± 0.254	Unités : mm, °, grs	
Designation : CHECK VALVE W/6PSI ±15% SPRING PRESSURE	PROMEPLA		
FOR035-1			