

ECHELLE: 1:1

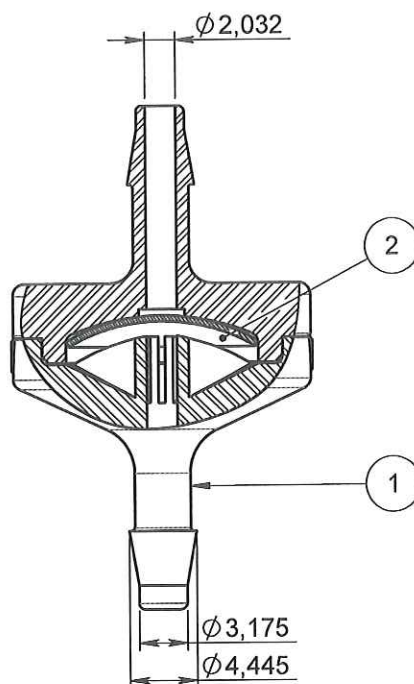

NOTA:

Rep	Matière	Code matière
1	PP	M1303
2	Silicone	M1304

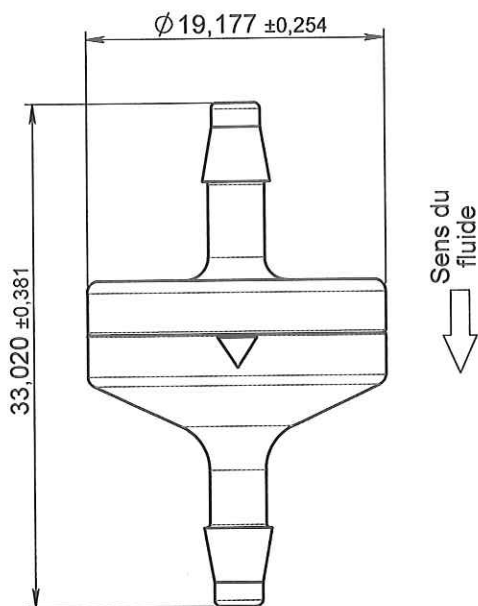

APPROBATION / APPROVAL		
Client / Customer :	Promepla Resp. BE :	Promepla Qualité :
FD 24.11.2016		
Nom, date et signature		

ORIGINAL

0	15/07/2017	RANDAZZO	Creation (Code proto 171012A)	FOR073: 6624
Rev.	Date	Designer	Modifications	N° Fiche FOR073 ou FOR021

Normes :

Matière : VOIR NOTA	P. 1 / 1	Echelle : 2:1	
Code matière : VOIR NOTA	Revision : 0	Format : A4	
Reference : PBN00599	Tolérances générales : ± 0.381	Unités : mm, °, grs	
Designation : 1/8ID X 1/8ID CHECK VALVE - VITON/ POLYPROPYLENE	PROMEPLA		FOR035-1