

COUPE A-A

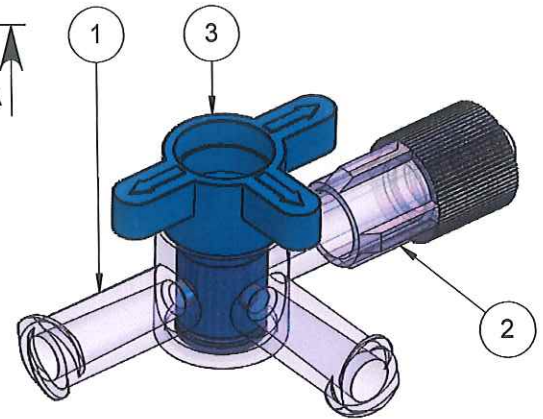
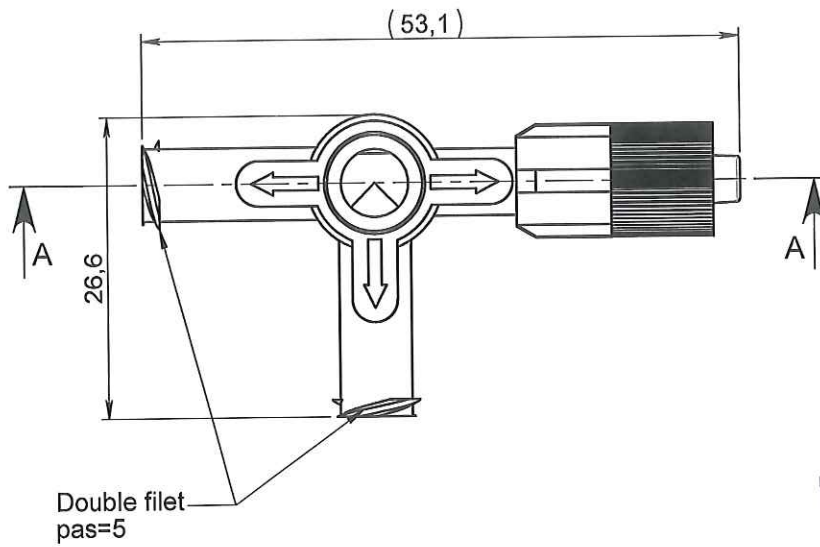
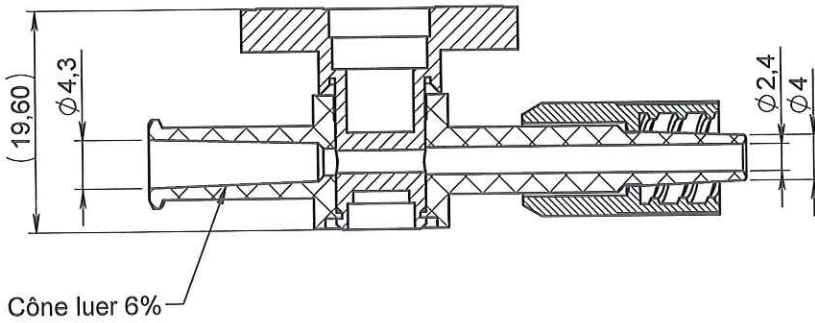

NOTA:

Rep.	Matière	Code matière
1	PMP	M0276
2	PC	M0177
3	PEHD +Colorant	M0993 + M0782

ORIGINAL

APPROBATION / APPROVAL		
Client / Customer :	Promepla Resp. BE :	Promepla Qualité :
	<i>DANCHIO</i> 17.12.2013	<i>[Signature]</i> 23 AVR. 2014
Nom / Name, date & signature		

1	05/03/2013	BOUJMADA	Code matière maneton M0127 devient M0993+M0782. Mise à jour désignation et mise au format SW.	FOR021: 4713
Rev.	Date	Designer	Modifications	N° Fiche FOR073 ou FOR021

Normes : ISO 594 -1/-2

Matière : VOIR NOTA

P. 1 / 1

Echelle : 3:2

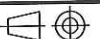

Code matière : VOIR NOTA

Revision : 1

Format : A4

Reference : HGQ08352

Tolérances générales :

Unités : mm, °, grs

Designation :
ROBINET 4 VOIES ON 360° - BLEU - LUER LOCK MALE
MOBILE

±0.3



FOR035-1