

COUPE A-A

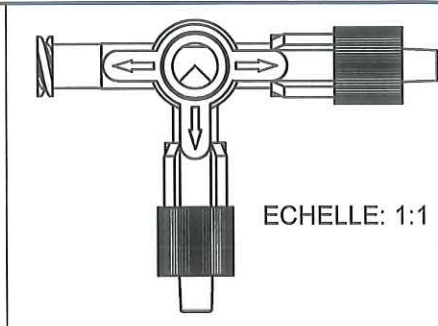

ECHELLE: 1:1

ORIGINAL

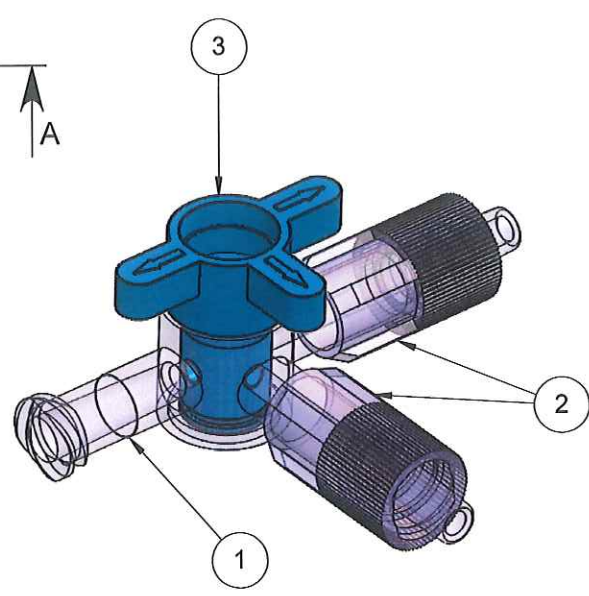
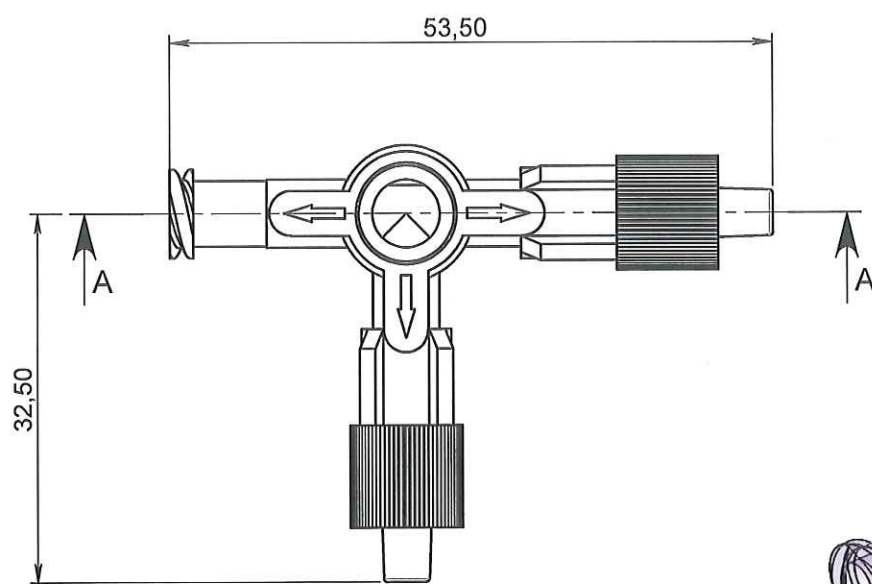

**NOTA:**

Rep.	Matière	Code matière
1	PC	M0260
2		
3	PEHD +Colorant	M0993 + M0782

APPROBATION / APPROVAL		
Client / Customer :	Promepla Resp. BE :	Promepla Qualité :
	FD 08.02.13	
Nom / Name, date & signature		

1	09/11/12	RANDAZZO	Code matière maneton M0127 devient M0993+M0782. Mise à jour désignation et mise au format SW.	FOR021: 4439
0	20/07/09	RANDAZZO	Creation	
Rev.	Date	Designer	Modifications	N° Fiche FOR073 ou FOR021

**Normes :**

Matière : VOIR NOTA	P. 1 / 1	Echelle : 3:2	
Code matière : VOIR NOTA	Revision : 1	Format : A4	
Reference : HGQ05322	Tolérances générales :	Unités : mm, °, grs	
Designation : ROBINET 4 VOIES ON 360° - BLEU - 1xLLF - 2x LUER LOCK MALE MOBILE	0-10mm = ±0.05 10-50mm = ±0.10 au delà = ±0.20	<b>PROMEPLA</b>	
		FOR035-1	