

ORIGINAL

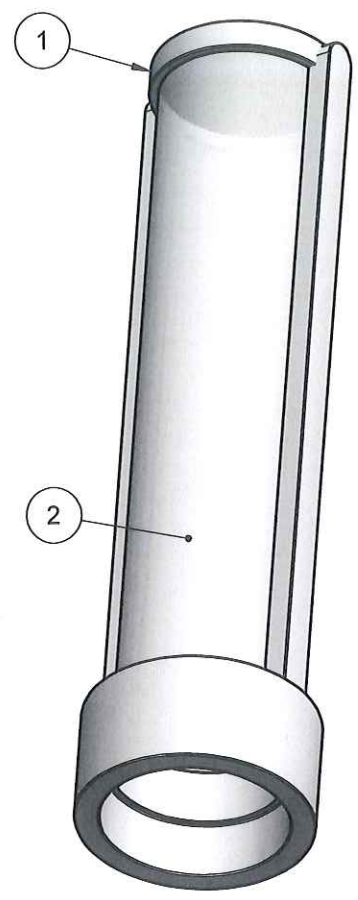

**NOTA :**

Ref	Matière	Code matière
1	PP	M0028
2	PA	M1278

APPROBATION / APPROVAL		
Client / Customer :	Promepla Resp. BE :	Promepla Qualité :
FD 24.11.2016		
Nom / Name, date & signature		

SPECIFICATION MAILLE	
Ouverture de maille	263 ±16µm
Ø du fil	100µm
Epaisseur	180µm

FILTRATION AREA : 15,8 cm<sup>2</sup>

Rev.	Date	Designer	Modifications	N° Fiche FOR073 ou FOR021
1	03/03/2016	RANDAZZO	Mise à jour cotation et graphique. Code matière M0214 devient M1278	FOR021 : 7530
0	07/07/2014	BOUJMADA	Creation	FOR073 : 8047

Normes :			
Matière : VOIR NOTA	P. 1 / 1	Echelle : 2:1	
Code matière : VOIR NOTA	Revision : 1	Format : A4	
Reference : EBC01040	Tolérances générales :	Unités : mm, °, grs	
Designation : FILTRE SANG 270µ - SURFACE DE FILTRATION 18cm <sup>2</sup>	Js16		
		FOR035-1	